

AM600 Motion Controller

High performance controller with EtherCAT interface and PLC functionality

- Can be easily expanded to meet customer requirements
- Able to control up to 32 axes
- PLCopen library available for motion control functionality
- InoProShop programming environment (IEC 61131-3)

EtherCAT®



LISTED
E467465
IND. CONT. EQ.

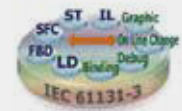

AM600 hardware overview

Inovance PLC range

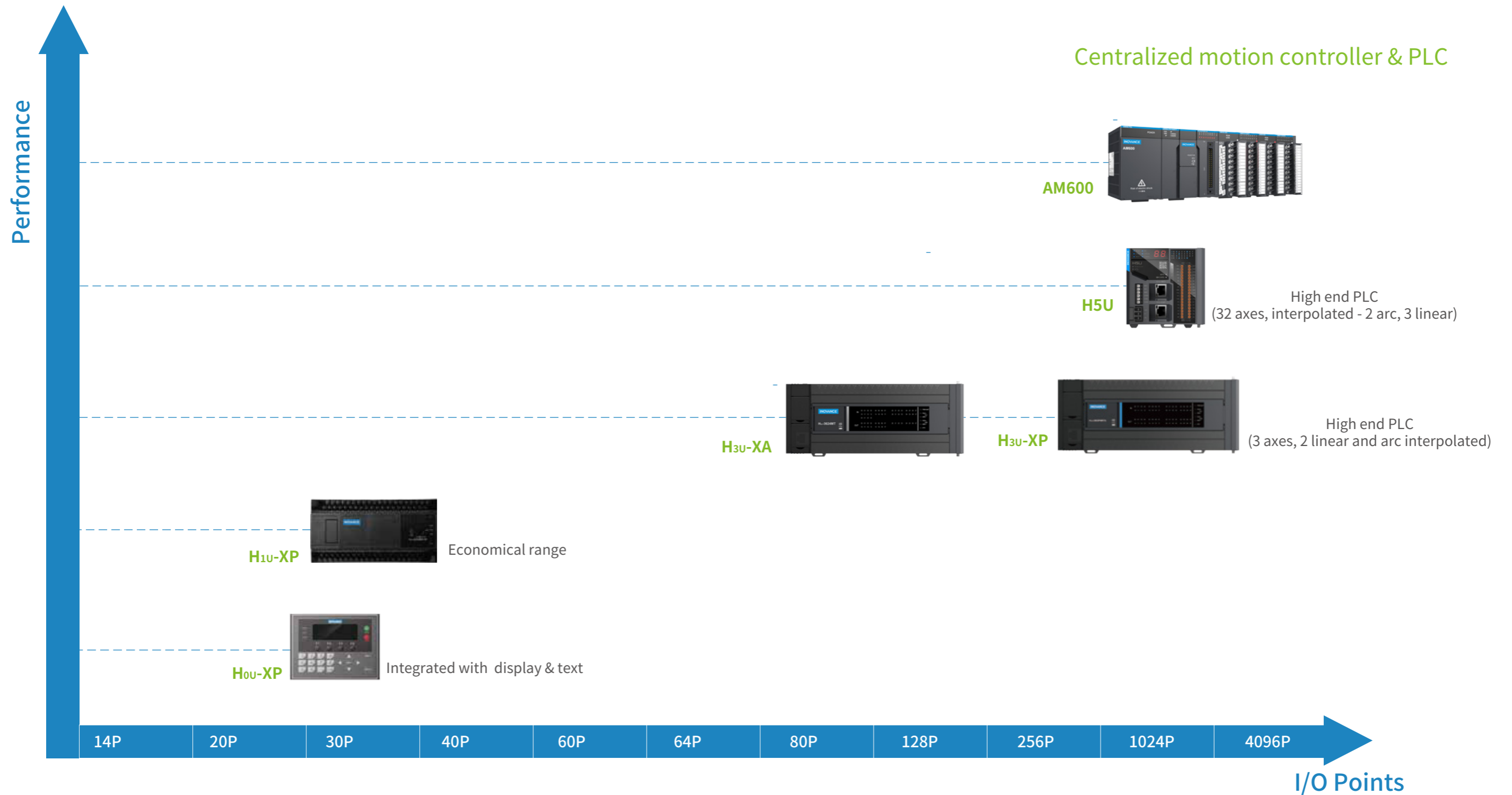

AM600 motion controller overview

- The EtherCAT bus of the AM600 main module supports 32 servo drives with a refresh time of 4 ms (for PTP positioning)
- It can realize CAM control of up to 16 axes and offers a synchronization period of 2 ms

AM600 EtherCAT topology

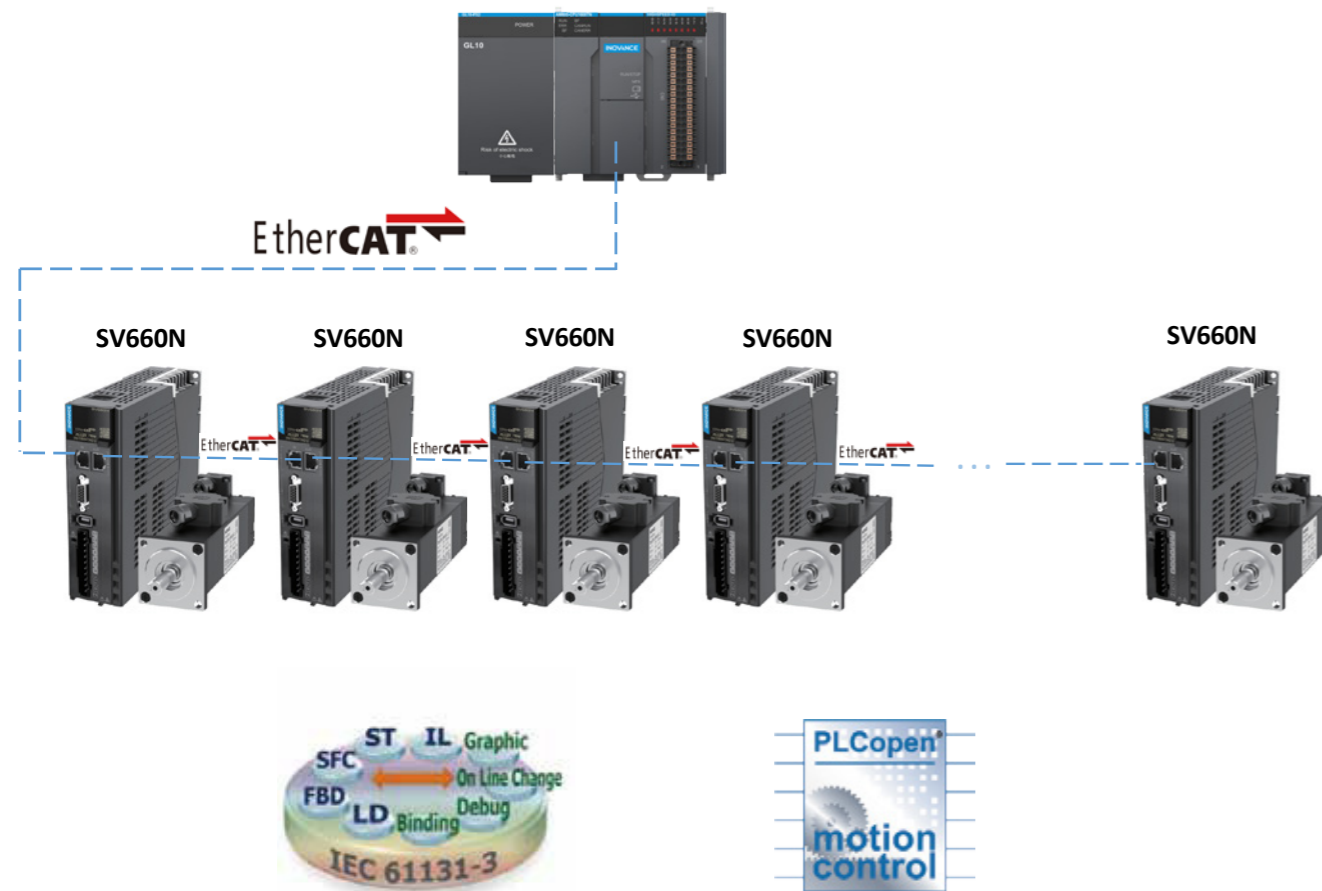

AM600 is a centralized motion controller with built-in PLC functionality. It has a standard EtherCAT port to control up to 32 axes with point-to-point positioning. A PLCopen library for single axis and interpolation movement is a standard feature. Every axis can be programmed to move using linear, circular or electronic cams (up to eight simultaneously). IEC 61131-3 programming (CODESYS) is part of the InoProShop software tool. Additional modules can be added to the main CPU module to be able to manage different I/O input types. CANopen functionality and an Ethernet port also come as standard. AM600 also supports EtherCAT connections to third party devices.

AM600 system setup



Local extension modules (GL): digital inputs, digital outputs, analog modules, temperature detection modules



Remote EtherCAT extension modules (GR): I/O modules, analog modules, temperature modules



*Alternative +24VDC power supply can be used. In that case an additional connector is required (not supplied with the CPUs/couplers).

AM600 features & functions

- Up to 32 axes for point-to-point positioning (up to eight for interpolated motion)
- ARM-Cortex A8 1 GHz
- Operates with mathematical precision – IEEE 754 double
- Built-in EtherCAT port
- Up to 16 additional I/O modules for every CPU
- Linear, circular and spherical interpolation (up to eight axes)
- CAM functionality
- Built-in Ethernet interface
- Modbus TCP/IP
- OPC UA protocol supported (server)
- CANopen/Modbus RTU interface
- IEC 61131-3 programming languages (CODESYS)
- Encoder input
- Simulated encoder output
- Multitasking functionality
- RoHS, CE certified

- EtherCAT CiA 402 motion profile supported
 - CSP
 - CSV
 - CST
 - HM
 - PP
 - PV
 - PT
- PLCopen functionality
 - PTP
 - Interpolated motion
 - CAM generator
 - Homing function
- Up to 125 slave stations can be added
- InoProShop software with IEC 61131-3 programming languages



PLCopen library for point-to-point positioning and interpolation

InoProShop software tools
Based on IEC 61131-3



EtherCAT slave extension modules for additional I/Os

EtherCAT CiA 402 profile



DIN rail mounting



PC-based software
InoProShop

EtherCAT

CANopen



AM600 – CPU1608TP EtherCAT

Main features:

- 24 VDC voltage input
- SD memory card
- Built-in EtherCAT port
- Two RS485 interfaces, supporting Modbus RTU protocol
- CANopen master
- CANlink master/slave
- Modbus TCP master/slave
- OPC UA protocol supported (server)
- 16-point high-speed input
- 8-point high-speed output
- 4 Mbytes user program storage
- Standard Ethernet cable for programming
- Programming software tools: InoProShop
- Physical dimensions: W x H x D = 80 x 90 x 95 mm
- Ethernet/IP scanner/adaptor



Dimensions:

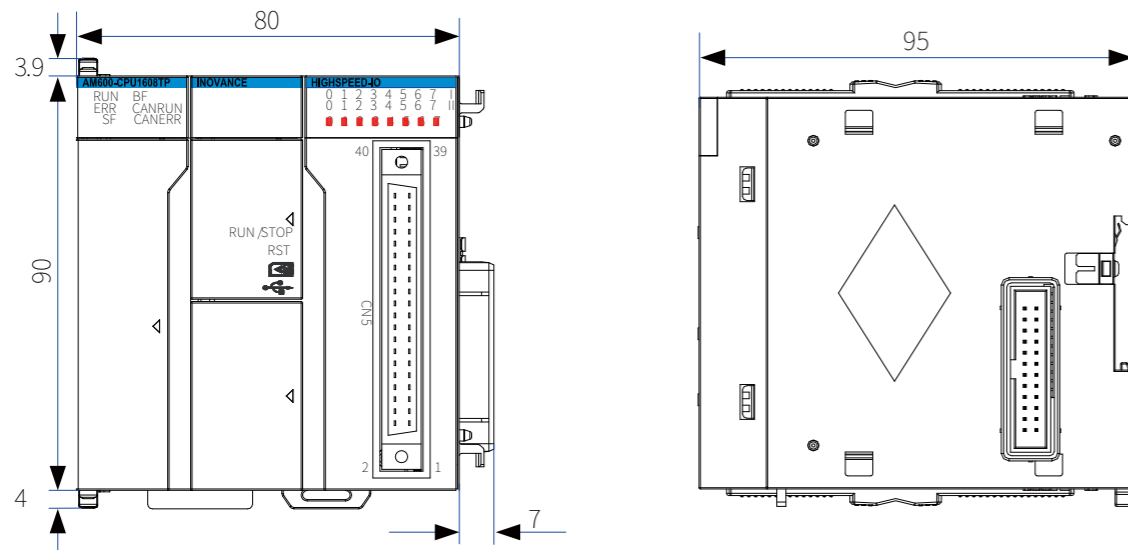

AM600 CPU module is equipped with:

- 8-channel A/B phase pulse counter; each channel offers a maximum of 200 kHz
- Pulse frequency/width measure, $\pm 2 \mu s$ accuracy
- Ethernet communication cable for commissioning and service

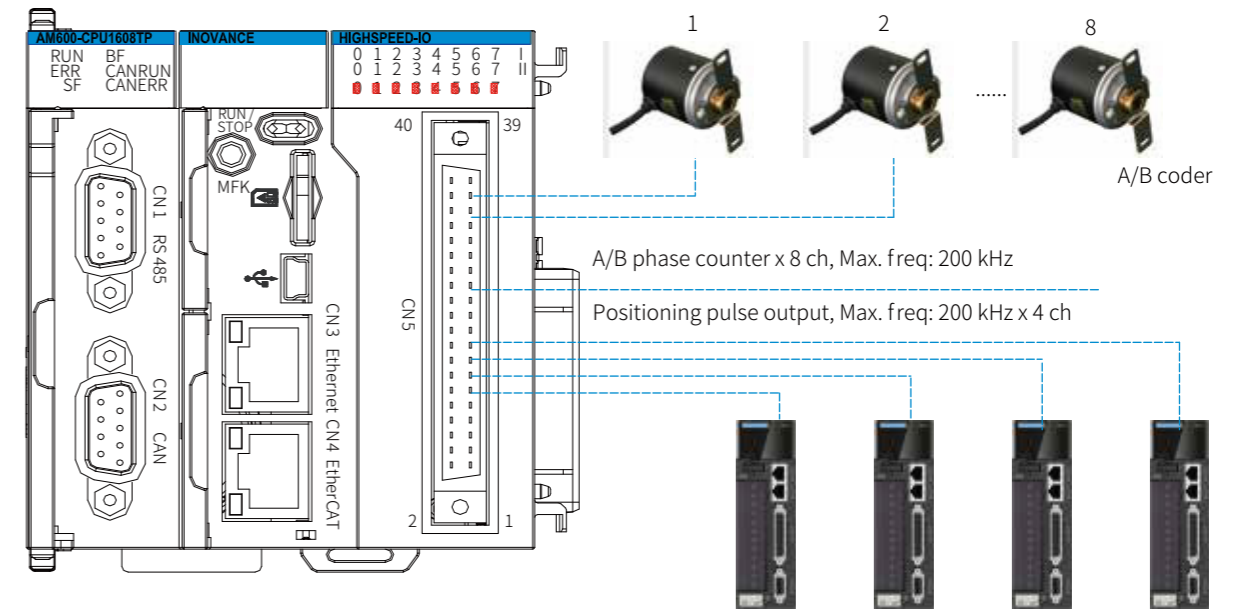

Monitoring via Ethernet connection

- Network diagram: The Ethernet interface of the CPU module can perform point-to-point connections to computers, HMIs and equivalent devices via an Ethernet connection

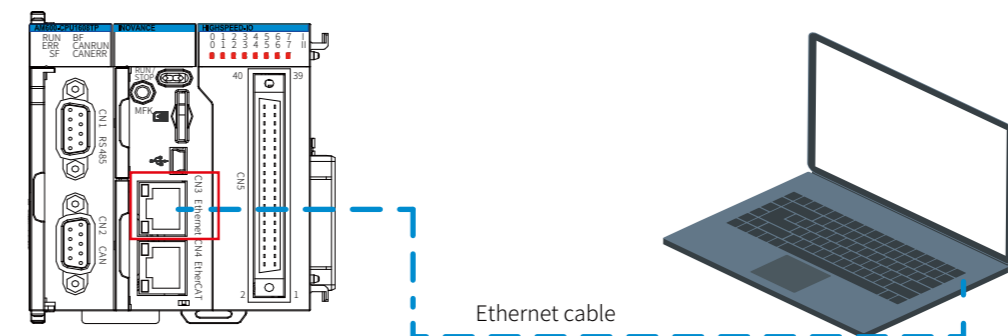

AM600 EtherCAT bus coupler slave module (GL10-RTU-ECTA)

- EtherCAT bus slave coupler extension (requires an AM600 master system)
- Up to 16 DI/DO modules or up to eight AI/AO modules can be added for each GL10-RTU-ECTA
- Supported services: CoE (PDO, SDO)
- Baud rate: 100 Mbit/s (100 Base-TX)
- Up to 125 modules can be added

Dimensions:

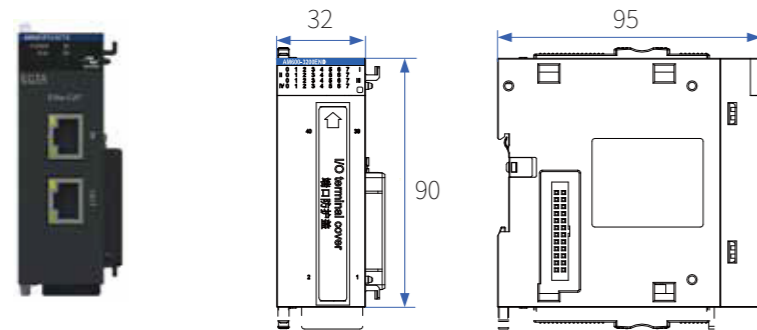

AM600 system (master)



Power supply module (GL10-PS2) (2)
 +
 EtherCAT bus coupler slave module (GL10-RTU-ECTA) (1)
 +
 Local extension modules (GL10-YYYY) (3)

Up to 125 modules



② ① ③ CE

Local extension modules (GL10 modules)

- AM600 extension modules are compact (32 mm thick) and can be added to the main CPU or to an EtherCAT Slave Bus Coupler
- Many different extension modules can be added (e.g. DIs, DOs, AIs, AOs, relays, temperature detectors)
- Physical dimensions:
W x H x D = 32 x 90 x 95 mm

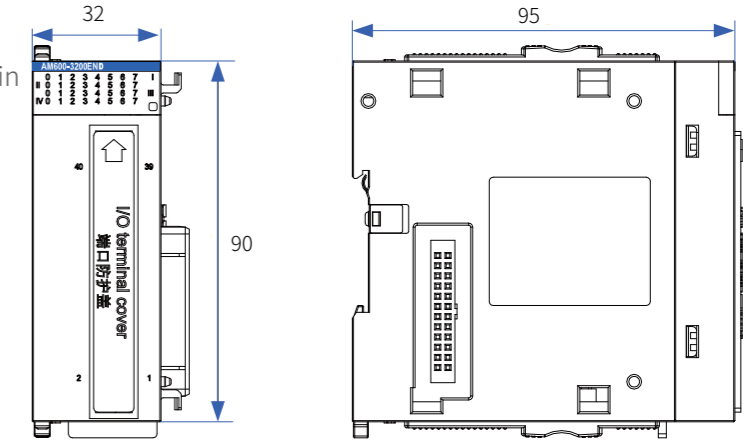

EtherCAT remote slave modules (GR10 modules)

- Up to 125 slave modules can be connected
- Supported services: CoE (PDO, SDO)
- Baud rate: 100 Mbit/s (100 Base-TX)
- Requires an external 24 VDC power supply

AM600 system (master)

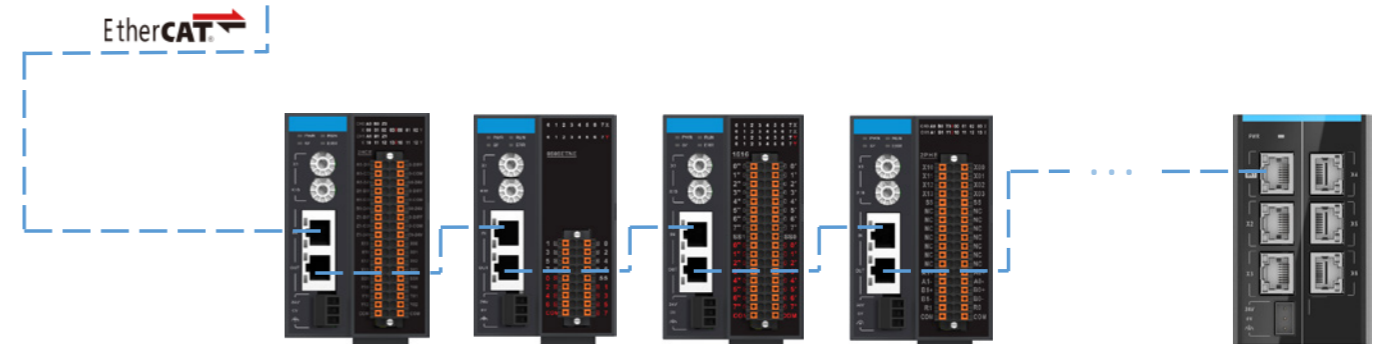

Up to 125 EtherCAT remote modules (slave)

EtherCAT network topology

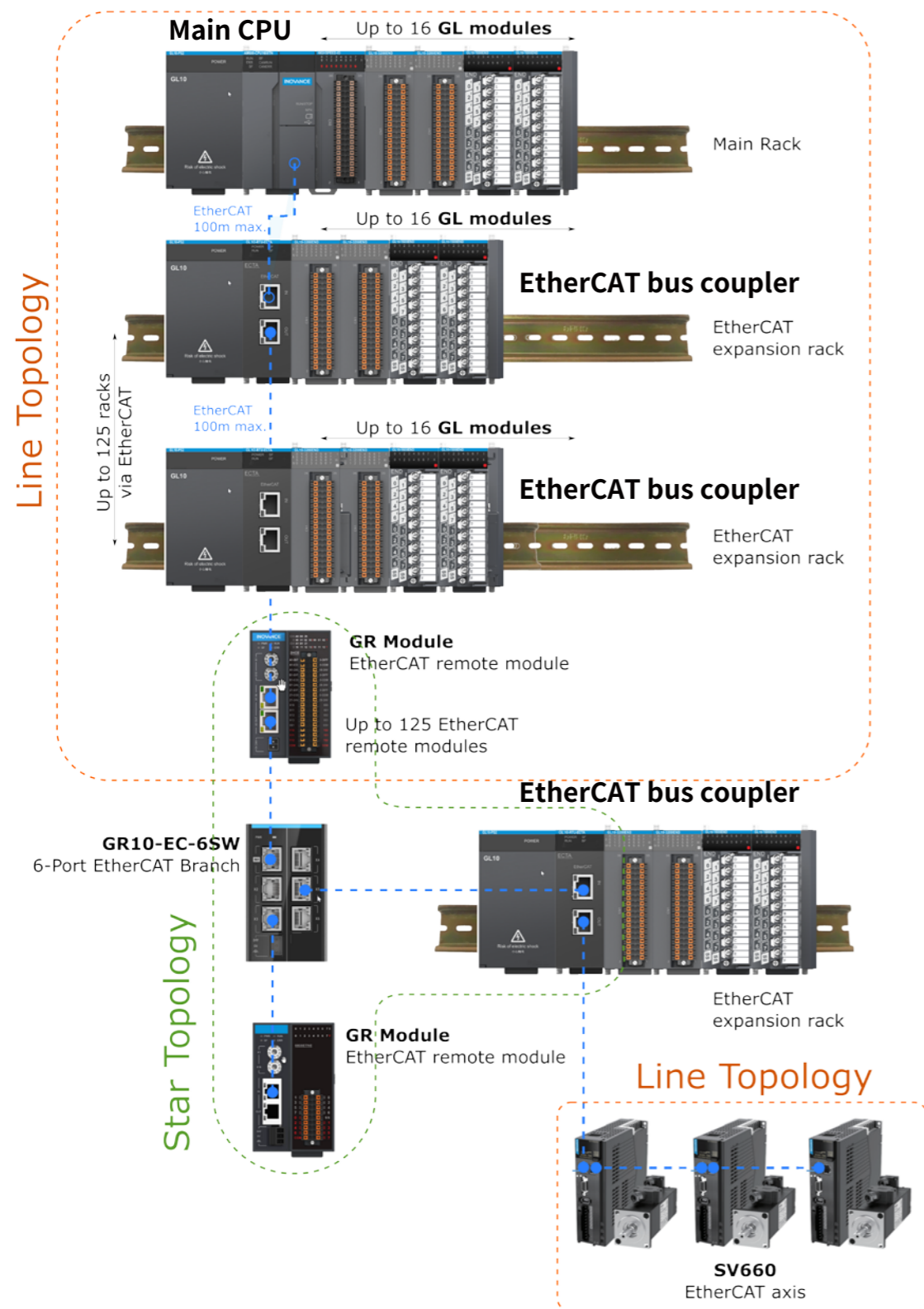

AM600 motion controller framework overview

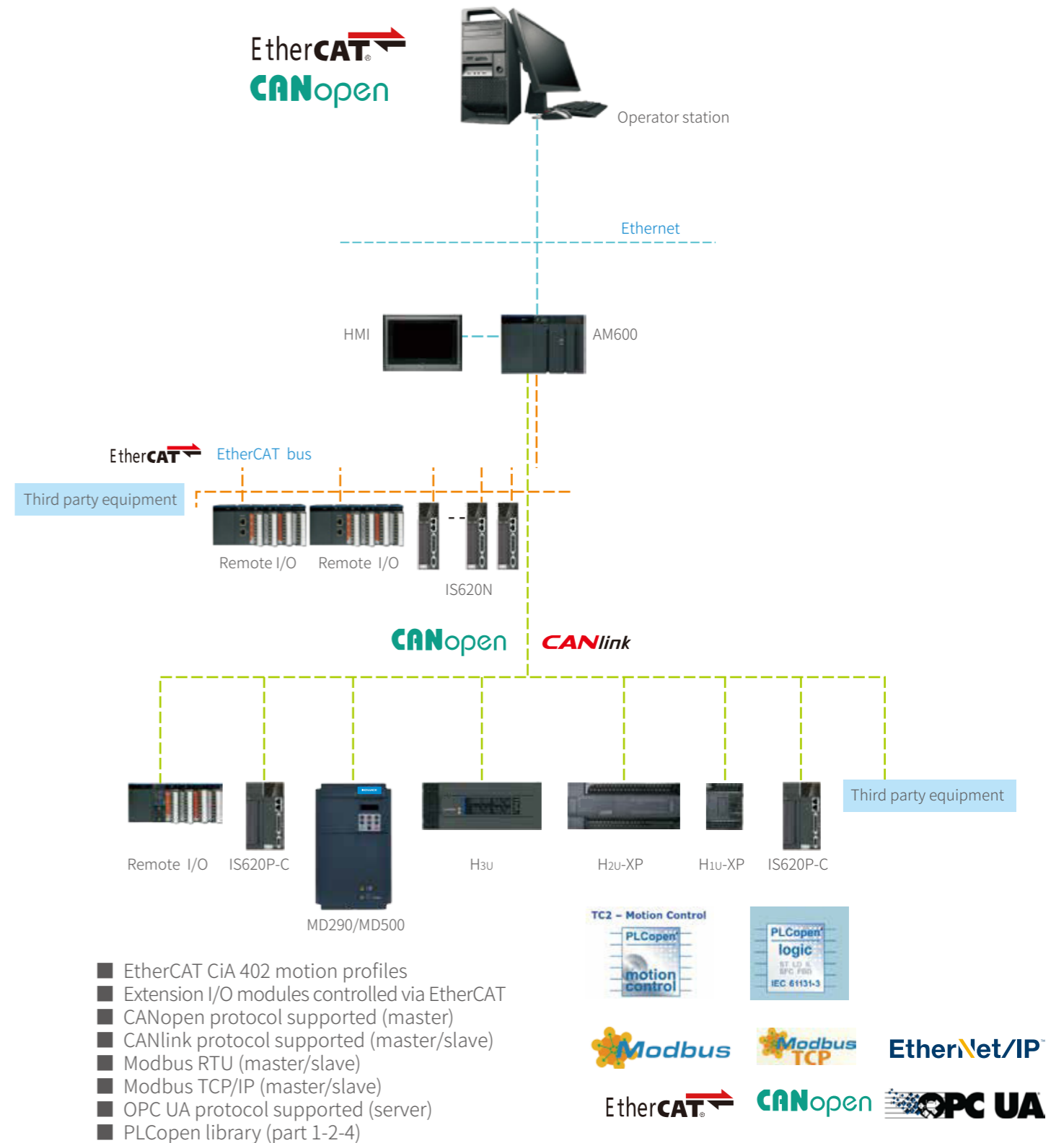

AM600 software overview

InoProShop software

- CAM tools as standard
- Scope tracing for monitoring and commissioning
- IEC 61131-3 standard programming languages for industrial applications
- Multi-task functionality

IEC 61131-3 standard – languages supported by InoProShop platform

- Structured Text (ST)
- Ladder Diagram (LD)
- Sequential Function Control (SFC)
- Continuous Function Chart (CFC)

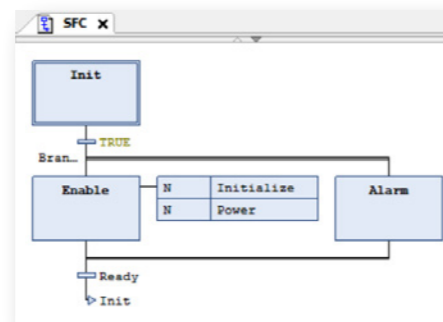
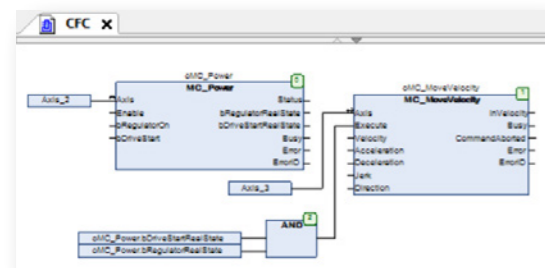
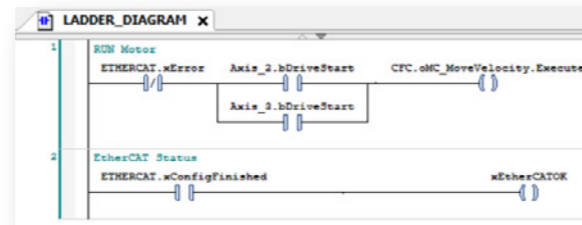
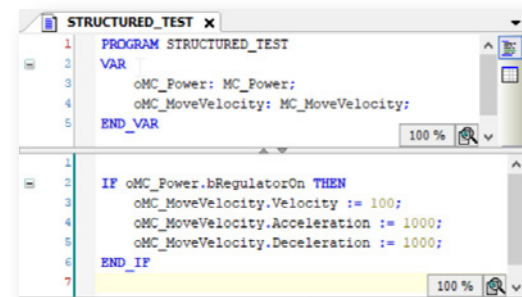

CAM setting

- CAM table can be easily configured by using the graphical editor included in InoProShop PC software
- Linear or polynomial interpolation (5th order polynomial)
- Supports up to 65535 CAM points

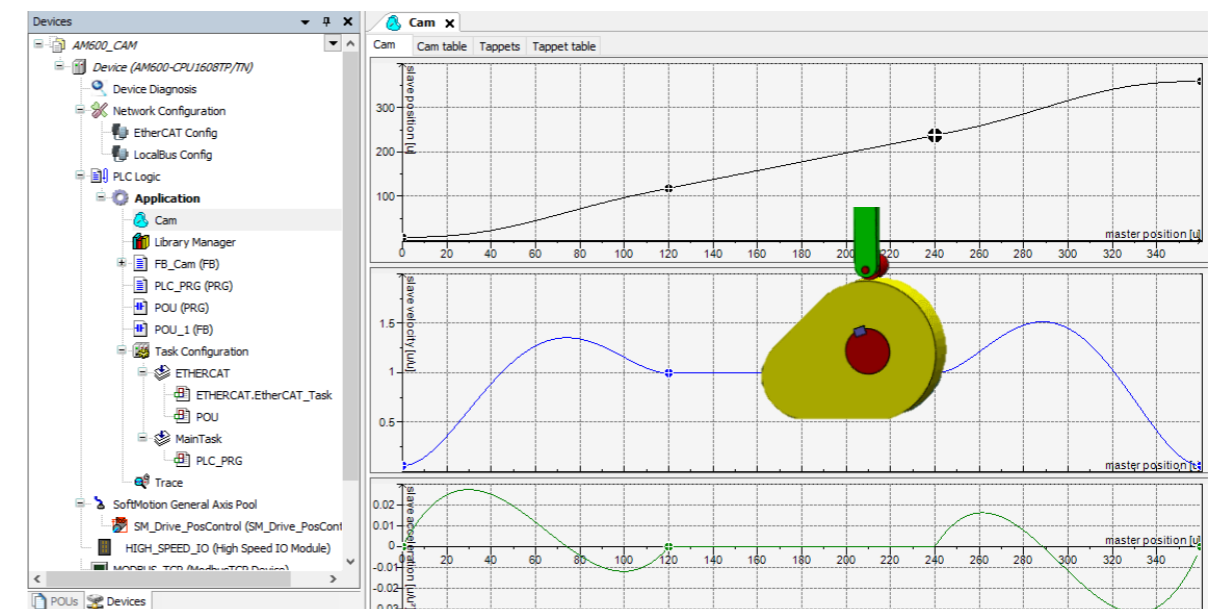
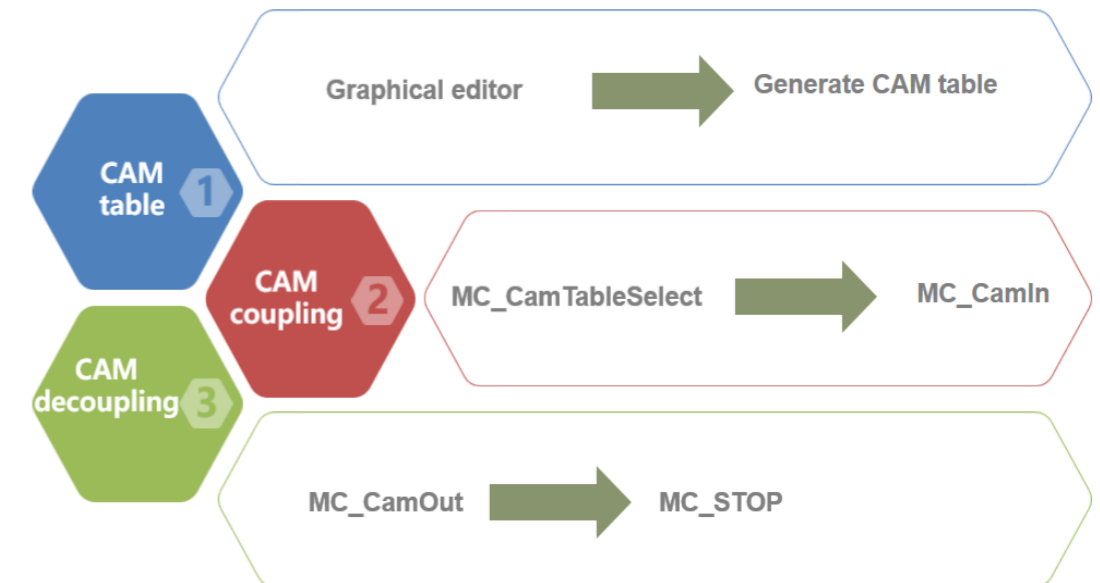

AM600 software overview

Network configuration

- EtherCAT easy axes configuration
- Diagram view of EtherCAT communications system
- Overview of all axes parameters by EtherCAT protocol

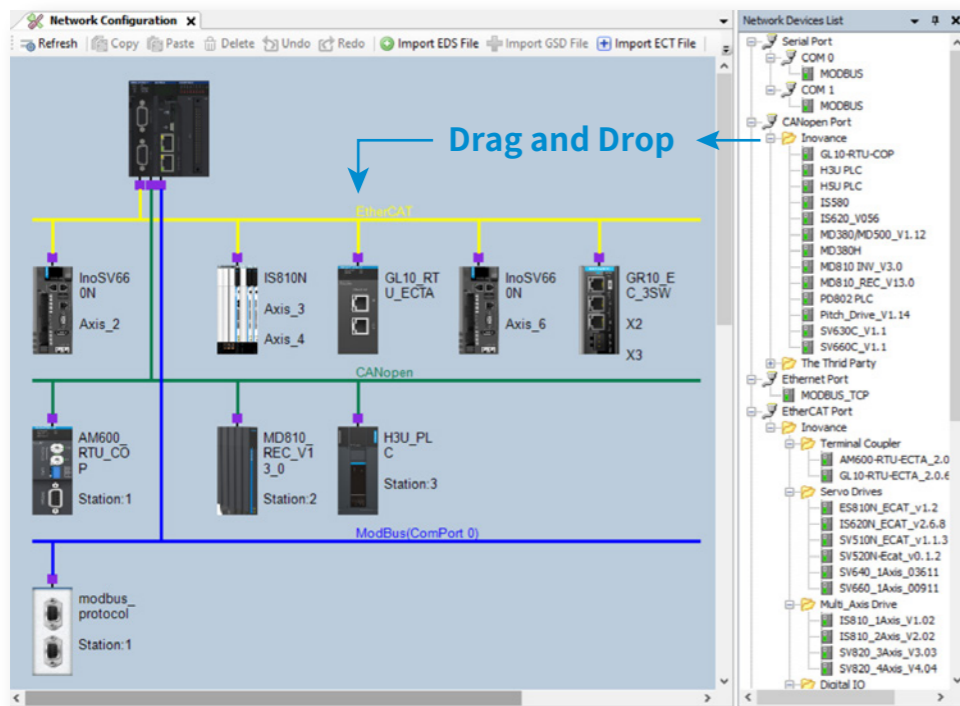

Axis commissioning and status

Axis status monitoring (for example, by position, velocity, or error information), allows intuitive axis configuration and enables online monitoring of program and axis variables via graphical curves

The interface shows configuration for 'Axis X'. It includes sections for General Setting, Scaling, Homing Setting, Mapping/Other Setting, Commissioning, and Status. A gear diagram shows a motor (M) connected to a workpiece (W) through gears (1), (2), (3), (4), and (5). The homing setting includes Homing methods (26), Homing Vel (10 pulse/s), Acceleration (100 pulse/s²), Homing Crawl Vel (2 pulse/s), and Time Limit (50000 *10ms). A timing diagram shows the homing switch signal, positive limit switch, and deceleration point signal.

Axes parameters

FunCode	Name	CurrentValue	Write	DefaultValue	Range
H08	Gain Parameters				
H08-00	Speed-loop Gain	400	400	400	1-20000
H08-01	Speed-loop integral time constant	2840	1989	15-51200	15-51200
H08-02	Position-loop Gain	362	640	1-20000	1-20000
H08-03	The second speed loop gain	750	750	1-20000	1-20000
H08-04	The second speed loop integral time constant	1061	1061	15-51200	15-51200
H08-05	The second position loop gain	1200	1200	1-20000	1-20000
H08-08	Second gain mode setting	1	1	0-1	0-1
H08-09	Gain switchover condition	0	0	0-10	0-10
H08-10	Gain switchover delay	50	50	0-10000	0-10000
H08-11	Gain switchover level	50	50	0-20000	0-20000
H08-12	Gain switchover hysteresis	30	30	0-20000	0-20000
H08-13	Position gain switchover time	30	30	0-10000	0-10000
H08-15	Average value of load inertia ratio	300	100	0-12000	0-12000
H08-17	Zero-Phase delay time	0	0	0-40	0-40
H08-18	Speed feedforward filter time constant	50	50	0-6400	0-6400
H08-19	Speed feedforward gain	0	0	0-1000	0-1000
H08-20	Torque feedforward filter time constant	50	50	0-6400	0-6400
H08-21	Torque feedforward gain	0	0	0-3000	0-3000
H08-22	Speed feedback filter	0	0	0-4	0-4

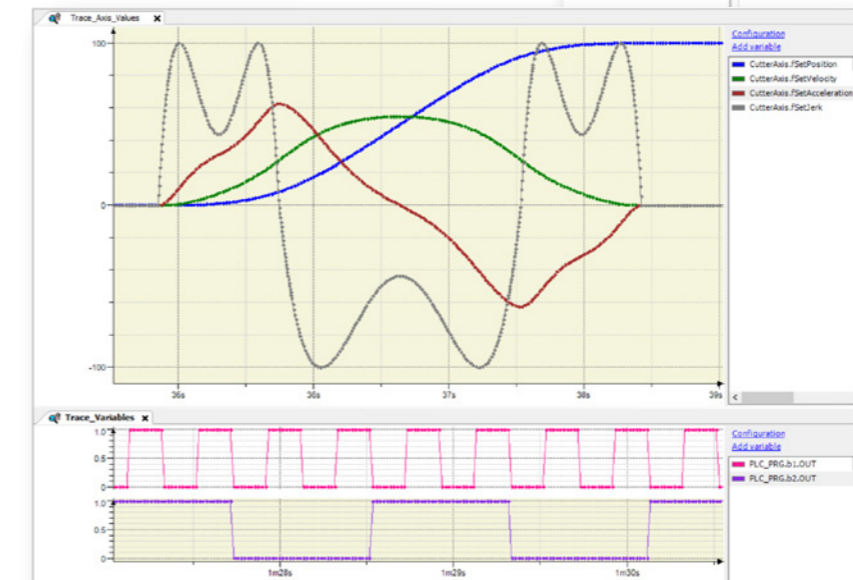

Model number	Item Code	CE	Description
CPU's			
AM401-CPU1608TP-INT	01440170	Yes	16 x high-speed inputs, 8 x high-speed outputs, source (PNP) type (requires connection cable, see below X210-5-X.X), 1 x RS485, 1 x CAN port, 1 x EtherCAT port, 1 x Ethernet port, 1 x USB, supports 4 axes control
AM402-CPU1608TP-INT	01440166	Yes	16 x high-speed inputs, 8 x high-speed outputs, source (PNP) type (requires connection cable, see below X210-5-X.X), 1 x RS485, 1 x CAN port, 1 x EtherCAT port, 1 x Ethernet port, 1 x USB, supports 8 axes control
AM600-CPU1608TP-INT	01440168	Yes	16 x high-speed inputs, 8 x high-speed outputs, source (PNP) type (requires connection cable, see below X210-5-X.X), 2 x RS485, 1 x CAN port, 1 x EtherCAT port, 1 x Ethernet port, 1 x USB, supports 32 axes control
AM401-CPU1608TN	01440032	Yes	16 x high-speed inputs, 8 x high-speed outputs, sink (NPN) type (pluggable spring clamp terminals connector, included), 1 x RS485, 1 x CAN port, 1 x EtherCAT port, 1 x Ethernet port, 1 x USB, supports 4 axes control
AM402-CPU1608TN	01440031	Yes	16 x high-speed inputs, 8 x high-speed outputs, sink (NPN) type (pluggable spring clamp terminals connector, included), 1 x RS485, 1 x CAN port, 1 x EtherCAT port, 1 x Ethernet port, 1 x USB, supports 8 axes control
AM403-CPU1608TN	01440126	Yes	16 x high-speed inputs, 8 x high-speed outputs, sink (NPN) type (pluggable spring clamp terminals connector, included), 1 x RS485, 1 x CAN port, 1 x EtherCAT port, 1 x Ethernet port, 1 x USB, supports 16 axes control
AM600-CPU1608TN	01440064	Yes	16 x high-speed inputs, 8 x high-speed outputs, sink (NPN) type (pluggable spring clamp terminals connector, included), 2 x RS485, 1 x CAN port, 1 x EtherCAT port, 1 x Ethernet port, 1 x USB, supports 32 axes control
POWER SUPPLY UNIT			
GL10-PS2-INT	01440196	Yes	Power supply module, input: 220 VAC, output: 2 A/ 24 VDC
DIGITAL INPUT MODULES			
GL10-1600END-INT	01440198	Yes	16 x source (PNP)/sink (NPN) digital inputs module, screw terminals
GL10-3200END-INT	01440216	Yes	32 x source (PNP)/sink(NPN) digital inputs module, pluggable spring clamp terminals
DIGITAL OUTPUT MODULES			
GL10-0016ER-INT	01440193	Yes	16 x relay outputs module
GL10-0016ETP-INT	01440199	Yes	16 x source (PNP) transistor outputs module, screw terminals
GL10-0016ETN-INT	01440195	Yes	16 x sink (NPN) transistor outputs module, screw terminals
GL10-0032ETN-INT	01440217	Yes	32 x sink (NPN) transistor outputs module, pluggable spring clamp terminals
ANALOG I/O MODULES			
GL10-4AD-INT	01440197	Yes	4 x analog inputs module, screw terminals
GL10-4DA-INT	01440192	Yes	4 x analog outputs module, screw terminals
TEMPERATURE DETECTION MODULES			
GL10-4PT-INT	01440258	Yes	4 x channel thermal resistance inputs temperature detection module, screw terminals
GL10-4TC-INT	01440263	Yes	4 x channel thermocouple inputs temperature detection module, screw terminals
GL10-8TC-INT	01440261	Yes	8 x channel thermocouple inputs temperature detection module, screw terminals
EtherCAT COUPLER			
GL10-RTU-ECTA-INT	01440194	Yes	EtherCAT (auto scan) communication module, RJ45 LAN port
CANopen COUPLER			
GL10-RTU-COP-INT	01440251	Yes	CANopen communication module, DB9 female
REMOTE MODULES (EtherCAT SLAVE)			
GR10-2HCE-INT	01440206	Yes	Series programmable controller 2 channel ABZ high speed count EtherCAT slave station module, pluggable spring clamp terminals
GR10-0808ETNE-INT	01440249	Yes	8 x digital inputs and 8 x transistor outputs, sink (NPN) type, EtherCAT slave station module, pluggable spring clamp terminals
GR10-1616ETNE-INT	01440079	Yes	16 x digital inputs and 16 x transistor outputs, sink (NPN) type, EtherCAT slave station module, pluggable spring clamp terminals
GR10-2PHE-INT	01440256	Yes	2 x channel high-speed difference pulse output EtherCAT slave station module, pluggable spring clamp terminals
GR10-4ADE-INT	01440254	Yes	4 x analog inputs EtherCAT slave station module, pluggable spring clamp terminals
GR10-4DAE-INT	01440262	Yes	4 x analog outputs EtherCAT slave station module, pluggable spring clamp terminals
GR10-4PME-INT	01440252	Yes	4 x channel positioning output EtherCAT slave station module, pluggable spring clamp terminals
GR10-8PBE-INT	01440250	Yes	8 x channel capture probe EtherCAT slave station module, pluggable spring clamp terminals
GR10-8TCE-INT	01440257	Yes	8 x channel thermocouple inputs EtherCAT slave station module, pluggable spring clamp terminals
GR10-EC-6SW-INT	01440259	Yes	6 x channel EtherCAT branch module (1 EtherCAT input and 5 EtherCAT outputs), RJ45 LAN port
CONNECTION CABLES (For TP/TN type)			
H2U-USB-CAB	15041200	-	Connection of PC to controller, the connector on the cable is mini USB, length of 1.5 m
S6-L-T04-0.3	15040261	-	Ethernet cable, length of 0.3 M, speed of up to 100 Mbps, STP
S6-L-T04-3.0	15040262	-	Ethernet cable, length of 3 m, speed of up to 100 Mbps, STP
CONNECTION CABLES (Only for TP type)			
T024-K	15020452	-	40PIN MIL screw terminal block (required for TP type)
X210-5-0.5	15300119	-	AM600 I/O extension cable - 0.5 m length with 2 FCN connectors (required for TP type)
X210-5-2.0	15300193	-	AM600 I/O extension cable - 2.0 m length with 2 FCN connectors (required for TP type)

Driven by technology

AC drives



AC MultiDrives



MV drives



Single-Axis servos



Multi-Axis servos



Robotics & motion controllers



PLCs & HMIs



CNC machine tool solutions



Electric vehicle inverters

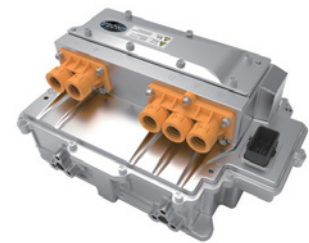

International Offices

☀ **Germany-Stuttgart**
Tel: +49 (0) 7144 8990
sales.de@inovance.eu

☀ **Italy-Milano**
Tel: +39 (0) 2268 22318
sales.it@inovance.eu

☀ **France-Bordeaux**
Tel: +33 (0) 5594 01050
sales.fr@inovance.eu

☀ **Turkey-Istanbul**
Tel: +90 (216) 706 17 89
info@inovance.eu

☀ **South Korea-Seoul**
Tel: +82 (0) 10 7428 5732
info@inovance.eu

☀ **India**
Head Office Chennai
Tel: +91 (0) 44 4380 0201

Ahmedabad
Tel: +91 (0) 79 4003 4274

Mumbai
Tel: +91 (0) 22 4971 5883

New Delhi
Tel: +91 (0) 11 4165 4524

Sales Network in Kolkata, Bengaluru,
Coimbatore, Hyderabad, Pune, Vadodara, Jaipur
Email: info@inovance.ind.in

☀ **Hong Kong SAR**
International Export Office
Tel: +852 2751 6080
info@inovance.eu

For other country distributors,
contact the Hong Kong office.

Inovance Technology Companies
Shenzhen Inovance Technology Co. Ltd.
Suzhou Inovance Technology Co. Ltd.

INOVANCE
www.inovance.eu